



**Metal Detector METAL SHARK FL**

High metal sensitivity  
Sensing width 200 - 8000 mm (4 in - 26 ft)

Conveyor installation below or above  
conveyed material

Applications:  
Plastic / foil production  
Panel board production  
Felt / textile / fleece production

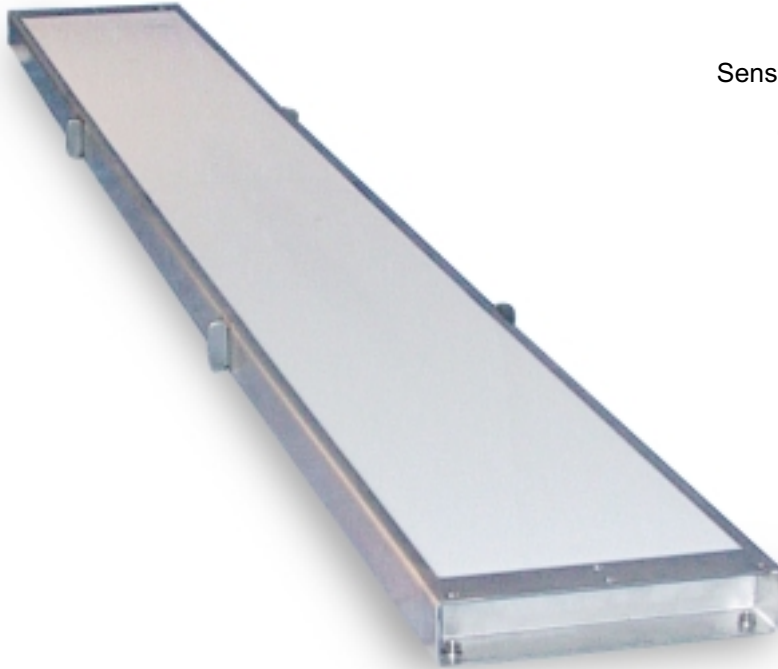

*Sensor head FL*



*Digital control unit SHARK*

## METAL SHARK FL

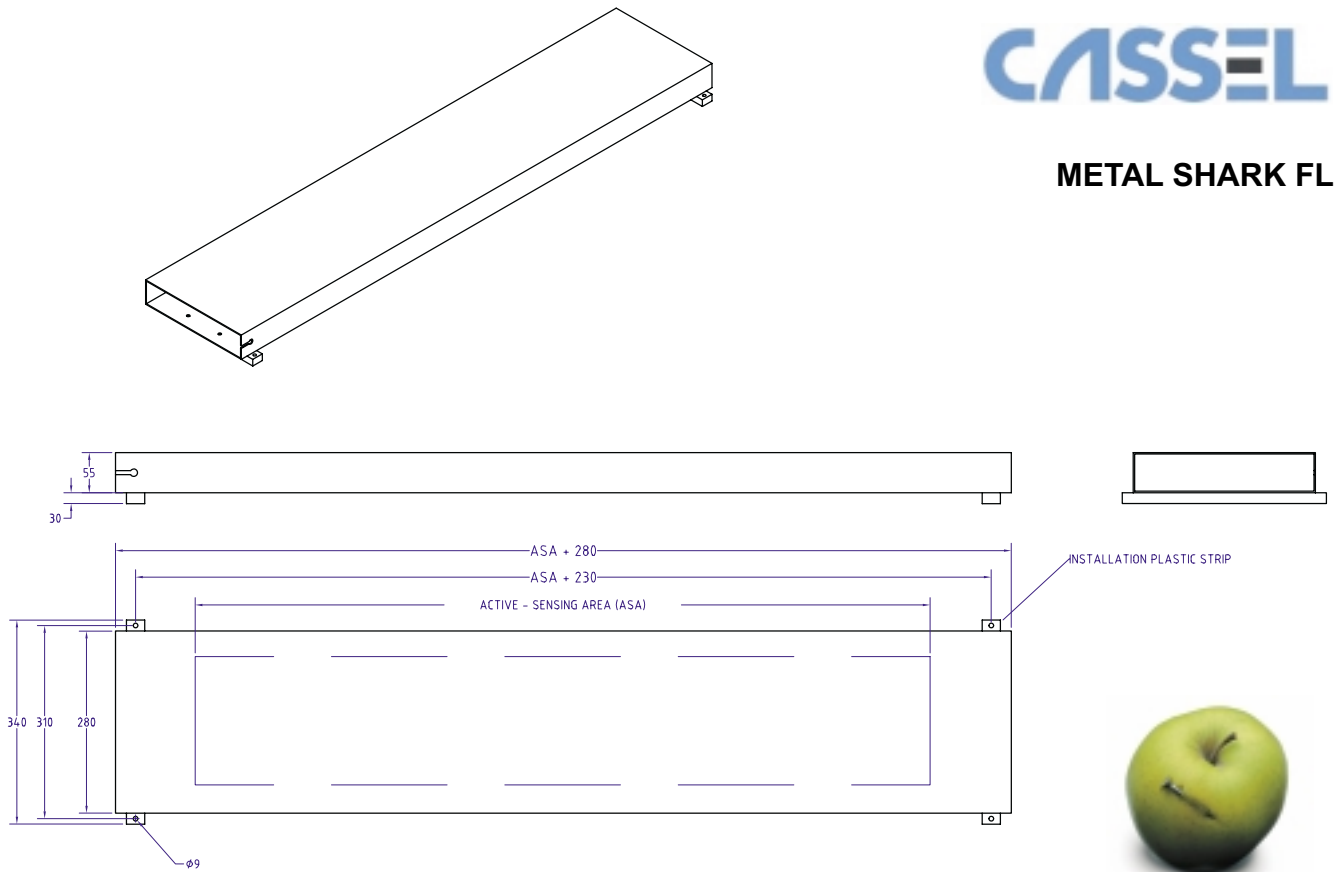

Type	METAL SHARK FL
Best Sensitivity *	
* depending on product effects and proper installation.	
Sensing width 200 - 1000 mm	
Height above sensor mm	10 20 30 40 50 60 70 80
Ferrous ball Ø mm	0,8 1,0 1,8 2,2 2,5 3,8 5,0 6,0
Sensing width 1000 - 4000 mm	
Height above sensor mm	10 20 30 40 50 60 70 80
Ferrous ball Ø mm	1,0 1,5 2,2 3,0 3,4 5,5 7,0 8,0
Non-Ferrous	1,2x Ferrous ball Ø
Stainless	1,5x Ferrous ball Ø
Installation	typical horizontal, but each angle is applicable
Metal free zone	Fix metal = 250 mm (10")
Before/after detector	Moving metal = 500 mm (20")
Power supply	85-264 V / 50-60 Hz
Power input	100 Watts
Ambient temperature	-10...+50 C / 15...120 F
Product (food) temperature	-20...+80 C / 0...180 F
Degree of protection	Control unit IP65 (Nema 4x, 12) Sensor IP67 (Nema 6P, 12)
Sensor head	Stainless steel housing
Control unit	Stainless housing, attached to the side of sensor head (Option: prepared for wall mounting, with link cable)

Link cable	2,5 m(8,2 feet), with cable protection tube, applies only with wall mounting option for the control unit
Timer	yes, for reject device control Delay and duration adjustable from 0-9990 ms
Conveyor speed	25 - 2000 mm/sec. (1" - 6,6 feet/sec.)
Out signals	Metal relay changeover contact (max 250V/1A) Metal alarm signal for PLC (out 24V/20mA) Fault relay changeover contact (max 250 V/1 A) Reject device drive, e.g. solenoid valve (24V DC/30mA)
In Signals	Reject trigger, e.g. optical sensor (24V DC) Control air pressure of reject device (24V DC) Control reject success (24V DC) Remote metal reset push button (24V DC) Remote lock keyboard against unauthorized access (24V DC)
Logging interface	Rs232, e.g. printer to log process data according HACCP Network interface Rs485 (Option)
Options	* Remote product selector switch * Customized conveyor design * Various belt types (Chain link, Polyurethan etc.) * Belt control unit Start/Stop/Reset with frequency inverter * Alarm flash light * Alarm horn